

Simple (Blade) Exit Light

MODEL: EX4LEDQE+

Feature

- PC+ABS light body.
- Quick Fit and Maintenance
- Suits 24m viewing distance.
- LED with a long life over 50000 hours energy-saving and environment friendly.
- Classification: C0/D25,C90/16
- Dimension (L x W x H):405x82x243mm.



BASE



EXRUN



EXARROW

Dimension

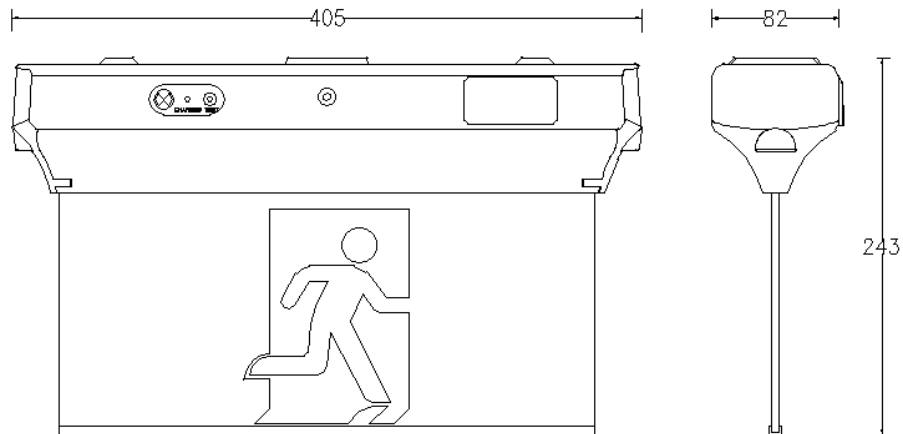

Technical parameters

NAME	RATED VALUE	UNIT
Supply Voltage	AC220-240	V
Supply Frequency	50	Hz
Power	7	W
Power Factor	0.55	
Ra	≥70	
Charge Time	16	Hours
Discharge Time	2	Hours
Ingress Protection Rating	IP20	
LED Lamp Life	50,000	Hours

Luminaire spacing

Luminaire classification	Maximum spacing													
	Mounting height (m)													
	2.1	2.4	2.7	3	3.3	3.6	4	4.5	5	6	7	8	9	10
C0/D25	14.2	14.7	15.3	15.7	16.1	16.5	16.9	17.3	17.7	18.1	18.3	18.2	17.9	17.3
C90/D12.5	11.5	11.5	11.8	12.1	12.4	12.5	12.7	12.9	13.0	12.8	12.3	11.3	9.9	7.6

Package

Net weight: 1.4kg/pcs

Inner box: 92*92*415(mm)

Carton box: 485*435*210(mm), 10pcs/carton

Installation instructions

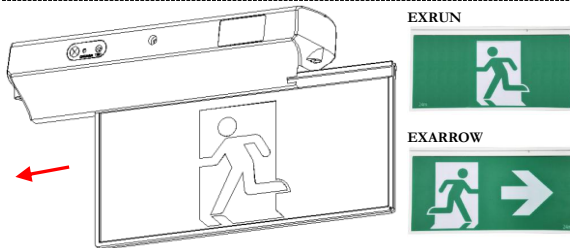

Choose the signage as need,
insert it to the box body

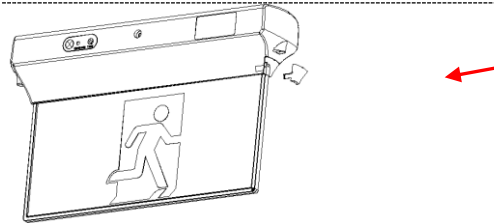

Fix base cover into the base
body

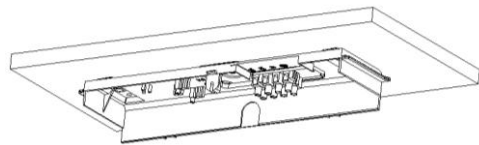

Install the Base plate on the
wall or on the ceiling first.
Connect the Mains cable to the
4 ports connector.

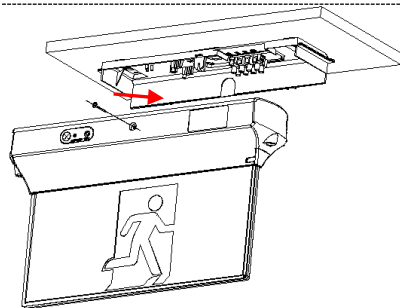

Fix the Base body with spare
screw